

PARALLEL 64K (8K x 8) EEPROM WITH SOFTWARE DATA PROTECTION

DATA BRIEFING

- FAST ACCESS TIME: 90ns
- SINGLE 5V ± 10% SUPPLY VOLTAGE
- LOW POWER CONSUMPTION
- FAST WRITE CYCLE:
 - 64 Bytes Page Write Operation
 - Byte or Page Write Cycle: 3ms Max
- ENHANCED END OF WRITE DETECTION:
 - Ready/Busy Open Drain Output (only on the M28C64)
 - Data Polling
 - Toggle Bit
- PAGE LOAD TIMER STATUS BIT
- HIGH RELIABILITY SINGLE POLYSILICON, CMOS TECHNOLOGY:
 - Endurance >100,000 Erase/Write Cycles
 - Data Retention >40 Years
- JEDEC APPROVED BYTEWIDE PIN OUT
- SOFTWARE DATA PROTECTION

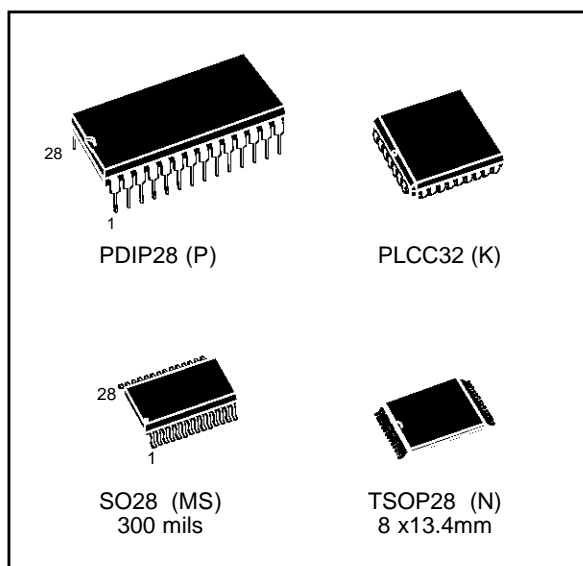

DESCRIPTION

The M28C64 is an 8K x 8 low power Parallel EEPROM fabricated with SGS-THOMSON proprietary single polysilicon CMOS technology. The device offers fast access time with low power dissipation and requires a 5V power supply.

Signal Names

A0 - A12	Address Input
DQ0 - DQ7	Data Input / Output
\bar{W}	Write Enable
\bar{E}	Chip Enable
\bar{G}	Output Enable
\bar{RB}	Ready / Busy
V _{CC}	Supply Voltage
V _{SS}	Ground

Logic Diagram

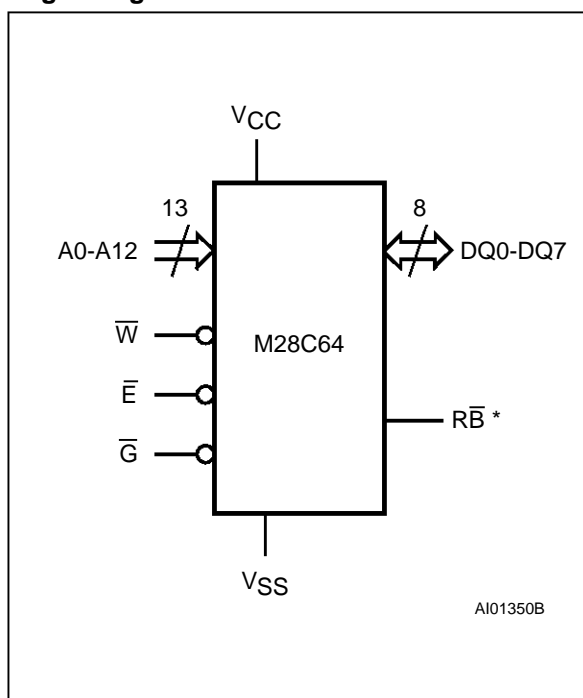

Note: * \bar{RB} function is only available on the M28C64.

M28C64

DIP Pin Connections

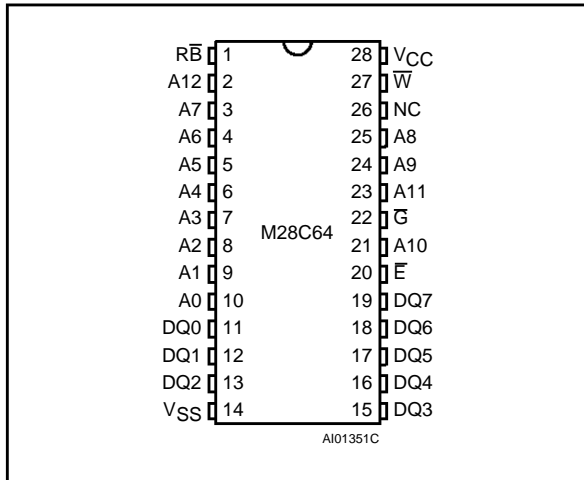

Warning: NC = Not Connected.

TSOP Pin Connections

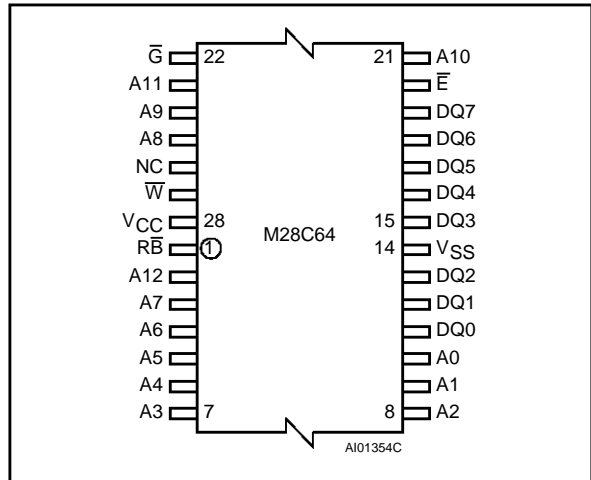

Warning: NC = Not Connected.

LCC Pin Connections

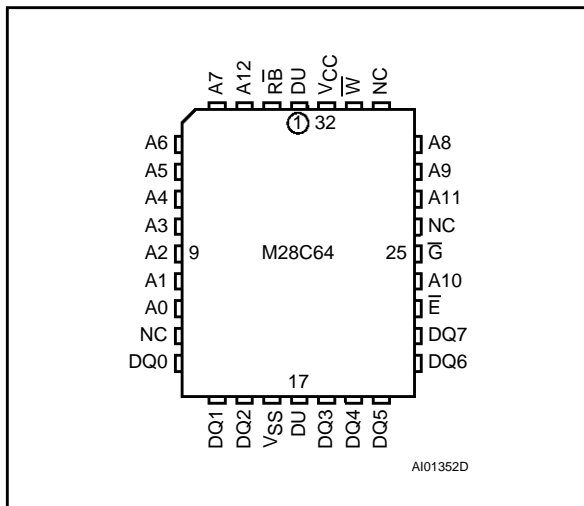

Warning: NC = Not Connected, DU = Don't Use.

SO Pin Connections

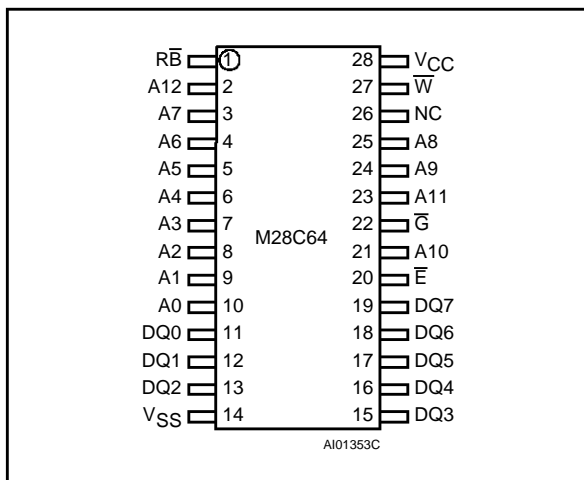

Warning: NC = Not Connected.

Ordering Information Scheme

For a list of available options refer to the current Memory Shortform catalogue.

For further information on any aspect of this device, please contact the SGS-THOMSON Sales Office nearest to you.

Example: M28C64 -90 X K 1

Speed	-90	X	K	1
-90	90ns			
-120	120ns			
-150	150ns			
Package				
blank	R \bar{B} function			
X	No R \bar{B} function			
Temp. Range				
P	PDIP28			
K	PLCC32			
MS	SO28 300mils			
N	TSOP28 8 x 13.4mm			
Option				
1	0 to 70 °C			
6	-40 to 85 °C			